

Hi-MO X6 Max

LR7-54HTH 455~470M

- Suitable for Distribution Market
- Simple design embodies modern style
- Highest efficiency with the best energy generation performance
- Better product warranty, better service



15-year Warranty for
Materials and Processing



25-year Warranty for Extra
Linear Power Output

Complete System and Product Certifications

IEC 61215, IEC 61730, UL 61730

ISO9001:2015: ISO Quality Management System

ISO14001: 2015: ISO Environment Management System

ISO45001: 2018: Occupational Health and Safety

IEC62941: Guideline for module design qualification and type approval

LONGI



23.0%
MAX MODULE
EFFICIENCY

0~3%
POWER
TOLERANCE

<1%
FIRST YEAR
POWER DEGRADATION

0.40%
YEAR 2-25
POWER DEGRADATION

Additional Value

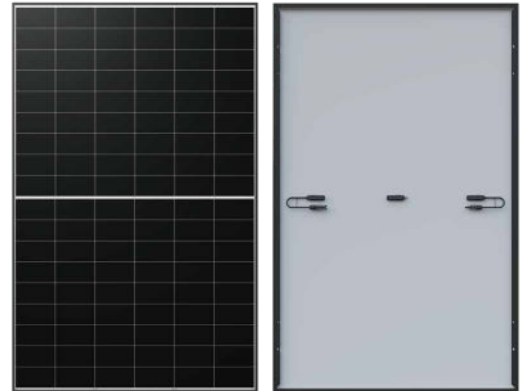
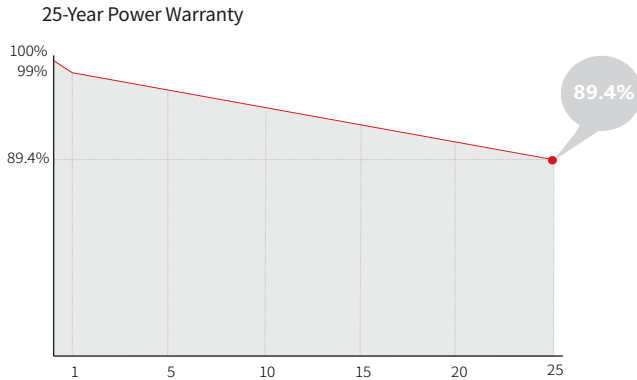

Mechanical Parameters

Cell Orientation	108 (6×18)
Junction Box	IP68
Output Cable	4mm ² , ±1200mm length can be customized
Glass	Single glass, 3.2mm coated tempered glass
Frame	Anodized aluminum alloy frame
Weight	21.6kg
Dimension	1800×1134×30mm
Packaging	36pcs per pallet / 216pcs per 20' GP / 864pcs per 40' HC

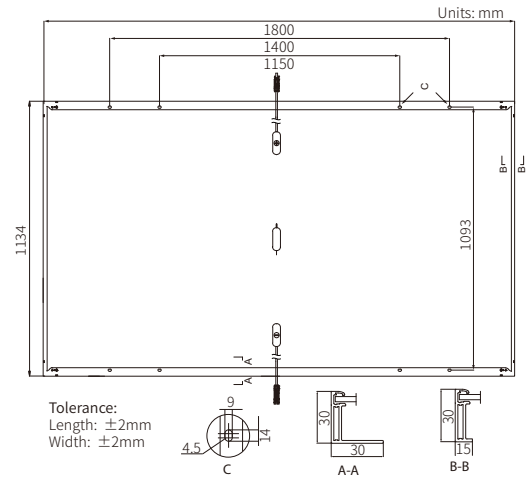

Electrical Characteristics

STC : AM1.5 1000W/m² 25°C NOCT : AM1.5 800W/m² 20°C 1m/s Test uncertainty for Pmax: ±3%

Module Type	LR7-54HTH-455M		LR7-54HTH-460M		LR7-54HTH-465M		LR7-54HTH-470M	
	STC	NOCT	STC	NOCT	STC	NOCT	STC	NOCT
Maximum Power (Pmax/W)	455	340.0	460	343.7	465	347.4	470	351.2
Open Circuit Voltage (Voc/V)	39.15	36.76	39.35	36.95	39.55	37.13	39.75	37.32
Short Circuit Current (Isc/A)	14.79	11.95	14.86	12.00	14.93	12.06	15.00	12.12
Voltage at Maximum Power (Vmp/V)	32.98	30.09	33.19	30.29	33.39	30.47	33.59	30.65
Current at Maximum Power (Imp/A)	13.80	11.30	13.86	11.35	13.93	11.41	13.99	11.45
Module Efficiency(%)	22.3		22.5		22.8		23.0	

Operating Parameters

Operational Temperature	-40°C ~ +85°C
Power Output Tolerance	0 ~ 3%
Maximum System Voltage	DC1500V (IEC/UL)
Maximum Series Fuse Rating	25A
Nominal Operating Cell Temperature	45±2°C
Protection Class	Class II
Fire Rating	IEC Class C

Mechanical Loading

Front Side Maximum Static Loading	5400Pa
Rear Side Maximum Static Loading	2400Pa
Hailstone Test	25mm Hailstone at the speed of 23m/s

Temperature Ratings (STC)

Temperature Coefficient of Isc	+0.050%/°C
Temperature Coefficient of Voc	-0.230%/°C
Temperature Coefficient of Pmax	-0.280%/°C